

# Broil King®

---

---



**Broil King**  
**BARON 590 IR SHADOW BUILT-IN**  
8766-82SDW  
8766-83SDW  
8766-86SDW

---

---

*Onward*  
SINCE 1906  
**MANUFACTURING COMPANY**  
585 KUMPF DRIVE LIMITED  
WATERLOO, ONTARIO, CANADA  
N2V 1K3

70084-E59EU REV D 09/25

# COUNTERTOP OPENING DIMENSIONS

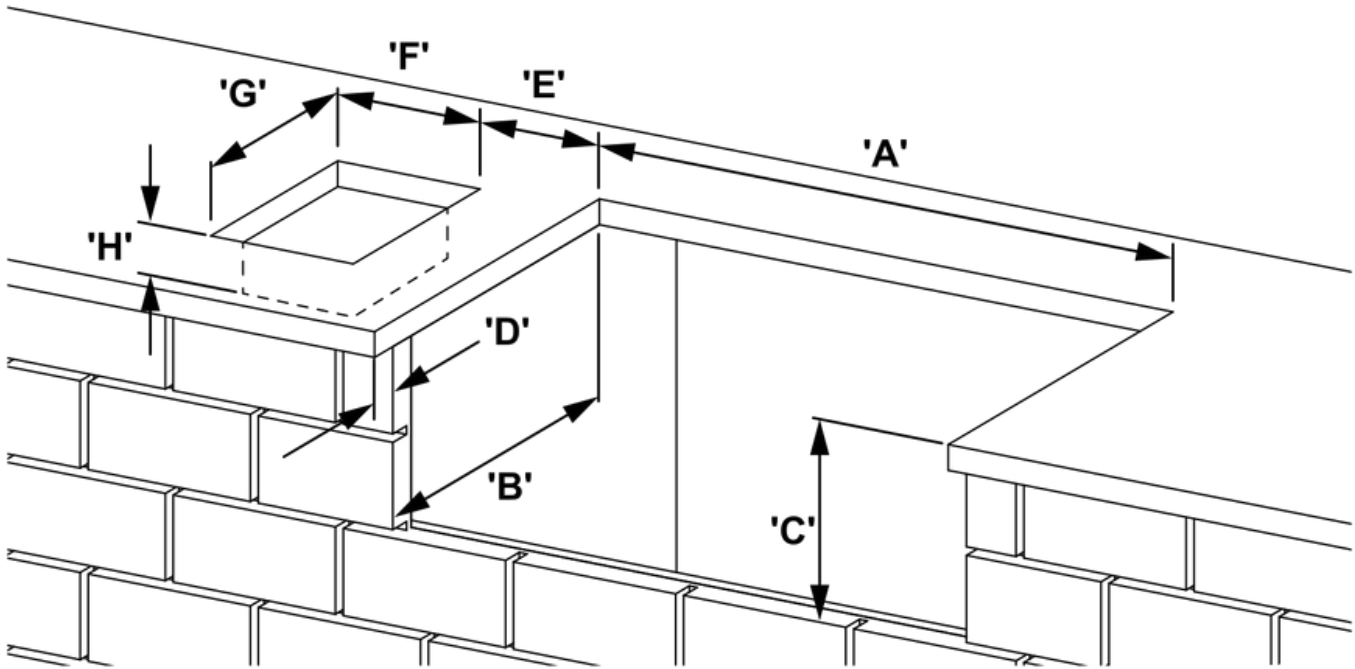

## COUNTERTOP OPENING DIMENSIONS BARON 590 IR BI Shadow

A	883 MM
B	464 MM
C	260 MM
D	Add overlap dimension "D" to countertop depth "B". Suggested overlap 1" [25 mm]
E	MIN [75 mm] – MAX [180 mm]
F	MIN. [290 mm] – MAX. [300 mm]
G	MIN. [370 mm] – MAX. [375 mm]
H	MIN [115 mm]

NOTE: The grease drawer should be flush to the front wall.

# INSTALLATION – CYLINDER & GRILL

## SPECIFICATION FOR CONNECTING TO A11kg GAS CYLINDER

- A 14" (350 mm) corrugated hose with a 3/8" SAE 45 degree fitting is connected to the manifold of the grill.
- Do not use pipe sealant on the 3/8" SAE 45 degree fitting.
- The 3/8" SAE 45 degree fitting must be attached to rigid permanent construction.
- If you choose to use a corrugated gas hose other than the one supplied, the connector must comply with EN ISO 228-1 or EN 10226-1 and EN 10226-2.

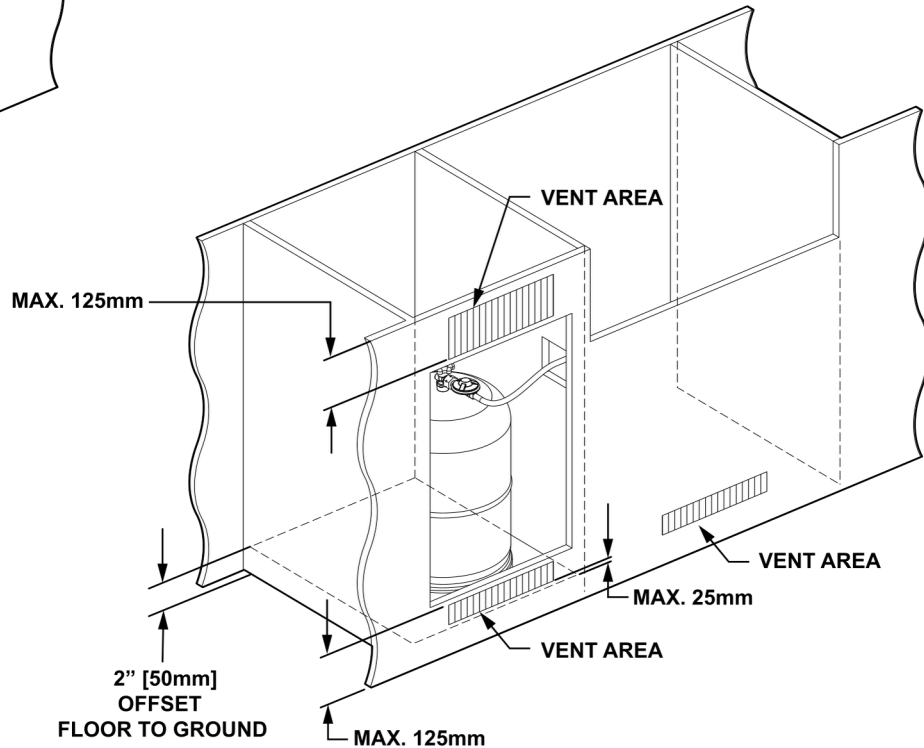
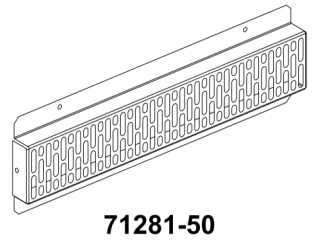
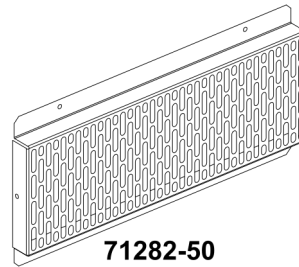
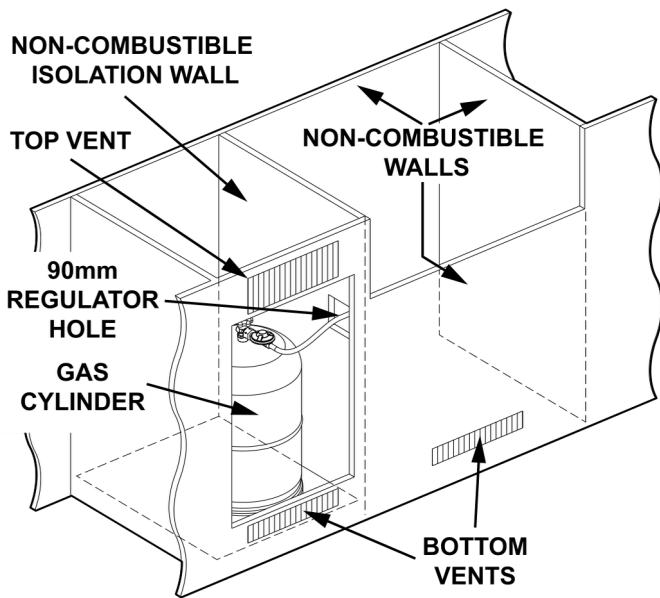
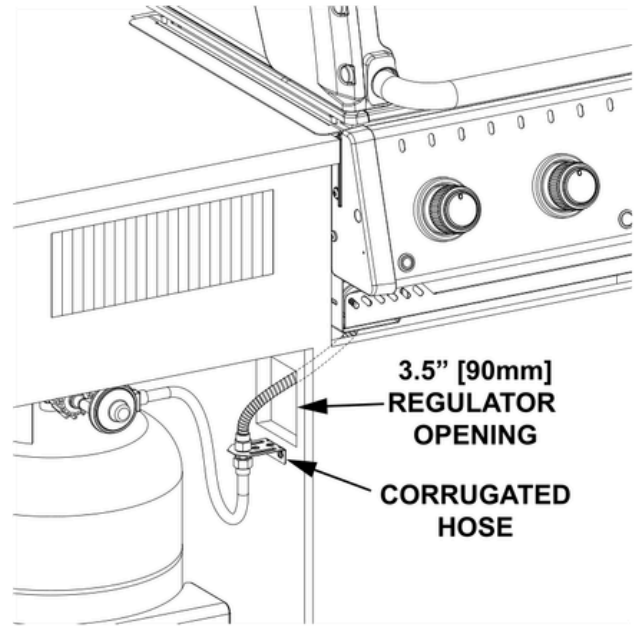

# SAFETY

## ELECTRICAL PRECAUTIONS

**WARNING! Failure to follow these instructions could lead to property damage, injury or death!**

- Input voltage 230-240Vac / 50Hz
- Output voltage 12Vac / 1600mA
- **Danger!** Immersing cords or plugs in water or other liquids could cause electrical shock!
- Unplug from power outlet when not in use and before cleaning or performing maintenance. Allow to cool before adding or removing components.
- Do not operate appliance if the cord, plug or any component is damaged or has malfunctioned in any manner. Contact the dealer for repair.
- If the supply cord is damaged it must be replaced before continuing to use the appliance
- Do not allow the cord to hang over the edge of a table or come into contact with hot surfaces.
- Do not use an outdoor gas appliance for any purpose other than intended.
- Connect the plug to the appliance before connecting to the power outlet.
- Only RCD (Residual-Current Device) protected circuits should be used with this outdoor cooking appliance.
- Do not remove the grounding plug or use with a two-prong adapter.
- Only use extension cords with a three-prong grounding plug, the correct power rating and approved for outdoor use with a W-A marking.

# INSTALLATION

## CONFIGURATION OPTIONS

There are many options for designing an outdoor kitchen for your new built-in gas grill. It can be a technically challenging project requiring skilled labor to plan and build.

**Installation and construction should be done by qualified professionals.**

- The built-in grill and all other accessory units should be on site before construction begins.
- If the grill will be paired with a side burner, position the side burner to the left of the grill.
- If the grill will be connected to a gas cylinder, position the gas cylinder to the left of the grill.

## ELECTRICAL OUTLETS

If a rotisserie will be used, an electrical outlet for the rotisserie should be positioned on the rear right side of the grill.

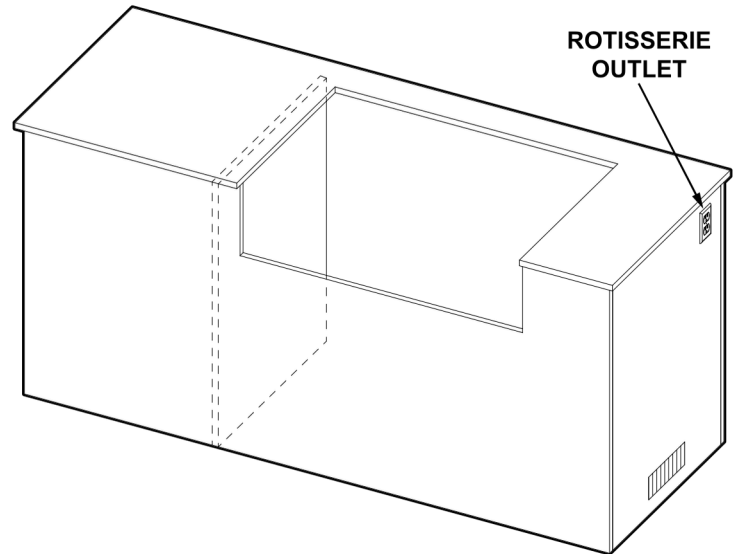

# INSTALLATION

The installation should be done by a qualified professional.

## POSITIONING YOUR GAS GRILL

Ensure there is adequate ventilation for heat and smoke to dissipate.

### WHEN DETERMINING THE POSITION OF THE GRILL, GIVE

#### THOUGHT TO:

- Exposure to wind.
- Proximity to traffic.
- Keeping gas lines and electrical connections as short as possible and away from heat sources.

#### LOCATE THE GRILL:

- To provide enough room to safely evacuate the area in the event of a fire.  
In a well-ventilated area.

#### NEVER LOCATE THE GRILL:

- In a garage, breezeway or shed, or any other enclosed area.
- Under overhead unprotected combustible construction.

The grill is designed to take air in through the control panel area and send the exhaust products out through the exhaust gap at the rear of the hood.

If locating the grill in a windy area, locate the grill so the prevailing wind will blow air at the front of the grill. A light wind blowing at the front of the grill will:

- Assist the grill in venting hot air thru the back of the grill.
- Assist in keeping smoke from blowing at someone who is cooking on the grill.

**WARNING:** Wind blowing in the back of the grill or along the exhaust vent can disrupt the proper flow of air through the grill, leading to reduced performance, or in certain cases, cause excess heat buildup in the control panel area. This can lead to a burn hazard if the control panel surface and knobs become too hot to touch.

During high wind conditions, it is best not to use the grill.

Damage to the grill resulting from use in windy conditions, such as melted knobs or igniter wires, or valve panel discoloration from heat build-up, are excluded from warranty coverage.

## CONSTRUCTION MATERIALS

Materials appropriate for outdoor construction should be chosen to build any enclosure and cabinetry for your built-in gas grill. All construction materials can be divided into two groups: combustible and non-combustible. You must follow the clearance specifications (pg4-6) for distances from the grill to either combustible or non-combustible materials.

## DEFINITION OF COMBUSTIBLE MATERIAL

compressed paper, plant fibers, vinyl/plastic or other materials that are capable of transferring heat or being ignited and burned. Such material shall be considered combustible even though flame-proofed, fire-retardant treated or surface-painted, or plastered.

## DEFINITION OF NON-COMBUSTIBLE MATERIAL

Material which is not capable of being ignited and burned, such as materials consisting entirely of, or a combination of, steel, iron, brick tile, concrete, slate, and plaster.

## COUNTERTOP

All installations require a non-combustible countertop surface. The countertop surface must be constructed from solid materials and must be level and smooth. For information on dimensions for openings in the countertop see (pg 10).

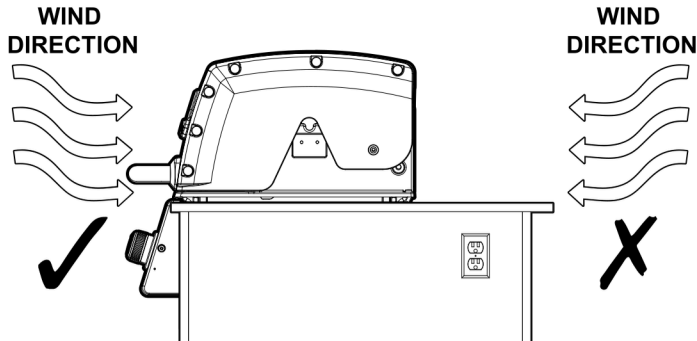

If the grill is located where the prevailing wind is blowing at the rear of the grill, a windbreak will need to be installed. The windbreak should be constructed to prevent wind from entering the exhaust vent in the rear of the grill and comply with the clearances specified for combustible or non-combustible construction as outlined in these instructions.

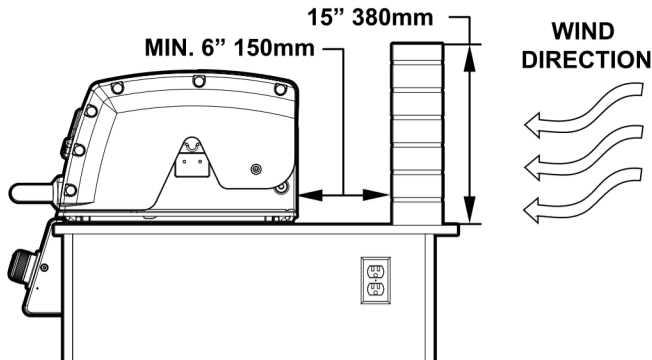

# INSTALLATION – CLEARANCES ABOVE COUNTERTOP

- A) Minimum clearance between the grill and non-combustible wall above the countertop surface is 6" [150mm] to the left, right and rear.

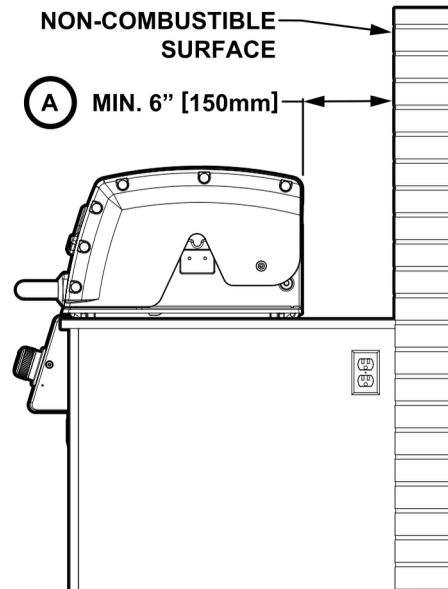

- B) Minimum clearance between the grill and a protected combustible wall above the countertop surface is 12" [300mm] to the left, right and rear.  
A protected combustible wall has a 1" (25mm) ventilated space between a non-combustible surface and the combustible surface extending 15" (375mm) above the countertop surface.

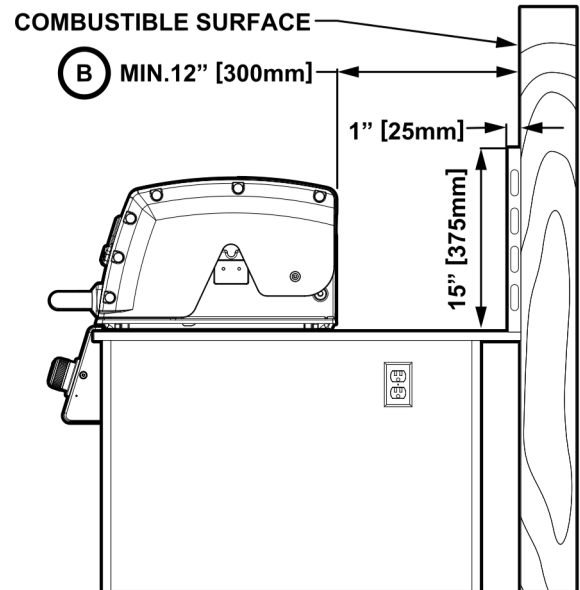

- C) Minimum clearance between the grill and a combustible wall above the countertop surface is 16" (400mm) to the left, right and rear.

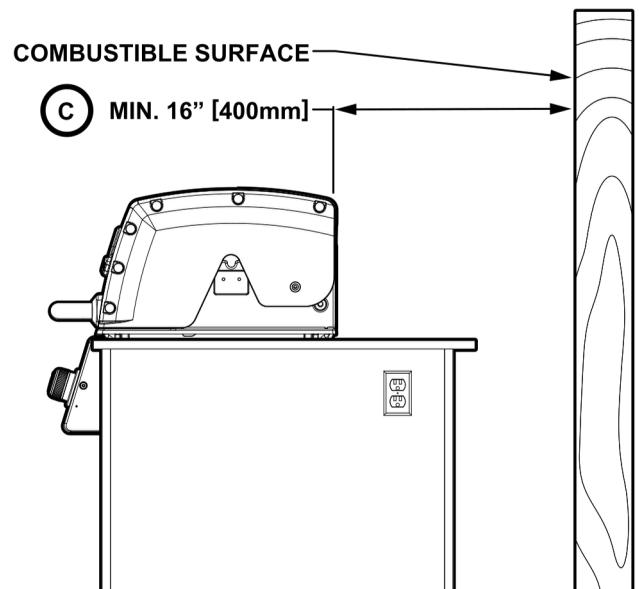

# INSTALLATION - CLEARANCES BELOW COUNTERTOP

D) Minimum clearance between the grill and any non-combustible wall below the counter topsurface is 1/4" (6mm) to the left, right, rear and bottom.

E) Minimum clearance between the grill and any protected combustible wall below the counter topsurface is 4" (100mm) to the left, right and rear.

A protected combustible wall has a 1" (25mm) ventilated space between a non-combustible surface and the combustible surface extending the full height below the countertop surface.

The non-combustible enclosure should be vented in accordance with guidelines on (pg 8) "Grill enclosures without LP gas cylinder".

